

Dimension

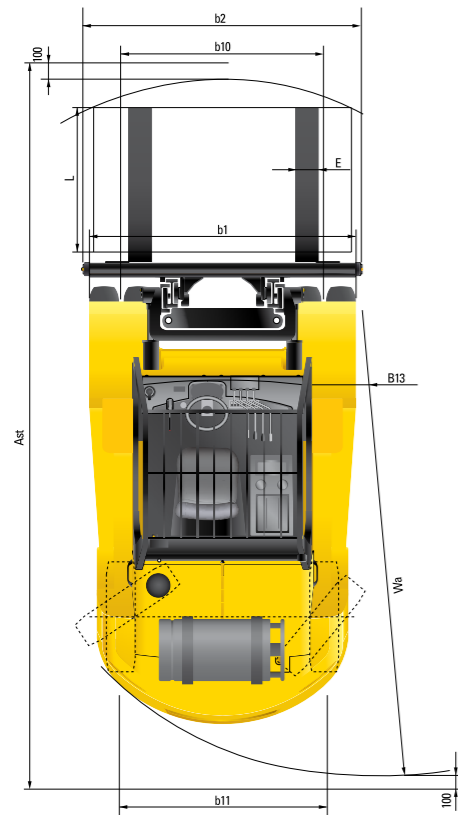

Specification

Identification			
1.1	Manufacturer	Hyundai	Hyundai
1.2	Manufacturer's type designation	60L-7A	70L-7A
1.3	Drive: electric (battery or mains), diesel, petrol, fuel gas, manual	LP	LP
1.4	Type of operation: hand, pedestrian, standing, seated, order-picker	seated	seated
1.5	Load capacity / rated load	Q (kg) 6,000	7,000
1.6	Load center distance	c (mm) 600	600
1.8	Load distance, center of drive axle to fork	x (mm) 615	615
1.9	Wheelbase	y (mm) 2,300	2,300
Weights			
2.1	Service weight	kg 8,862	9,430
2.2	Axle loading, loaded front/rear	kg 13,159 / 1,703	14,564 / 1,866
2.3	Axle loading, unloaded front/rear	kg 3,990 / 4,832	3,867 / 5,564
Wheels, Chassis			
3.1	Tires: solid rubber, superplastic, pneumatic, polyurethane	Pneumatic	Pneumatic
3.2	Tires size, front (width x ϕ)	8.25-15	8.25-15
3.3	Tires size, rear (width x ϕ)	8.25-15	8.25-15
3.5	Wheels, number front x rear (x=driven wheels)	452	452
3.6	Track width, front	b10 (mm) 1,578	1,578
3.7	Track width, rear	b11 (mm) 1,604	1,604
Basic Dimensions			
4.1	Mast / fork carriage tilt forward / backward (α/β)	degrees 15 / 10	15 / 10
4.2	Lowered mast height	h1 (mm) 2,515	2,515
4.3	Free lift	h2 (mm) 140	140
4.4	Lift height	h3 (mm) 3,030	3,030
4.5	Extended mast height	h4 (mm) 4,320	4,320
4.7	Overhead guard (cab) height	h5 (mm) 2,500	2,500
4.8	Seat height / standing height	h7 (mm) 1,395	1,395
4.12	Coupling height	h10 (mm) 425	425
4.19	Overall length	l1 (mm) 4,770	4,820
4.20	Length to face of forks	l2 (mm) 3,570	3,620
4.21	Overall width	b1 (mm) 2,087	2,087
4.22	Fork dimensions	s / e / l (mm) 65 x 150 x 1,200	65 x 150 x 1,200
4.23	Fork carriage ISO 2328, class / type A/B	Class IV	Class IV
4.24	Fork-carriage width	b12 (mm) 2,068	2,068
4.31	Ground clearance, loaded, under mast	m1 (mm) 195	195
4.32	Ground clearance, centre of wheelbase	m2 (mm) 220	220
4.33	Aisle width for pallets 1000x1200 crossways	Ast (mm) 5,136	5,185
4.34	Aisle width for pallets 800x1200 lengthways	Ast (mm) 5,336	5,385
4.35	Turning radius	Wa (mm) 3,321	3,370
4.36	Smallest pivot point distance	b13 (mm) 1,224	1,224
Performance Data			
5.1	Travel speed, Unloaded	km/h 22.5	22.4
5.2	Lift speed, Loaded/Unloaded	mm/s 420 / 420	420 / 420
5.3	Lowering speed, Loaded/Unloaded	mm/s 500 / 450	500 / 450
5.5	Drawbar pull, Loaded	kg 6,827	6,861
5.7	Gradient performance, Loaded	% 45.6	40.6
5.10	Service brake	Foot : Hydraulic	Foot : Hydraulic
Engine			
6.1	Engine manufacturer / type	GM 4.3L V6	GM 4.3L V6
6.2	Engine power acc. to ISO 1585	kW 70	70
6.3	Rated speed	1/min 2,300	2,300
6.4	No. of cylinder / cubic capacity	6 / 4,294	6 / 4,294
Other Details			
8.2	Type of drive control	Power Shift	Power Shift
8.3	Operating pressure	bar 185	185
8.4	Oil volume(system)	l 94	94
8.5	Noise	db(A) 82	82

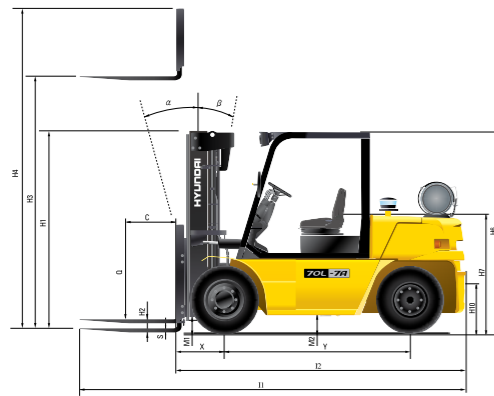

■ Some of the photos may include optional equipment.

HYUNDAI LPG FORKLIFT TRUCKS Applied Tier 4 Engine

60L/70L-7A

We build a better future

Beyond the Limits

Hyundai introduces a new line of 7A series LPG forklift trucks. Excellent power and performance make your business more profitable.



■ Some of the photos may include optional equipment.

The new master on the job-site!

Smooth running, efficient and ergonomically designed, 60/70L-7A series are made to meet your needs.

70kW/2,300rpm



Powerful Engine GM 4.3L V6 Engine

Market approved quality of GM 4.3L V6 engine ensures incomparable performance, durability and additional value to the machine. Powerful and efficient engine provides excellent fuel economy and excellent torque for improved operation.
(EPA/CARB Tier-IV Certified)

Fast and Stable Performance

Being able to quickly raise and lower the mast, as well as tilt it forward and backward, provides the best operational conditions during unloading.

When the truck is fully loaded, mast lowering speed is carefully controlled to ensure safety by the down control valve.

Mast(Lift and Tilt) Look System is standard.

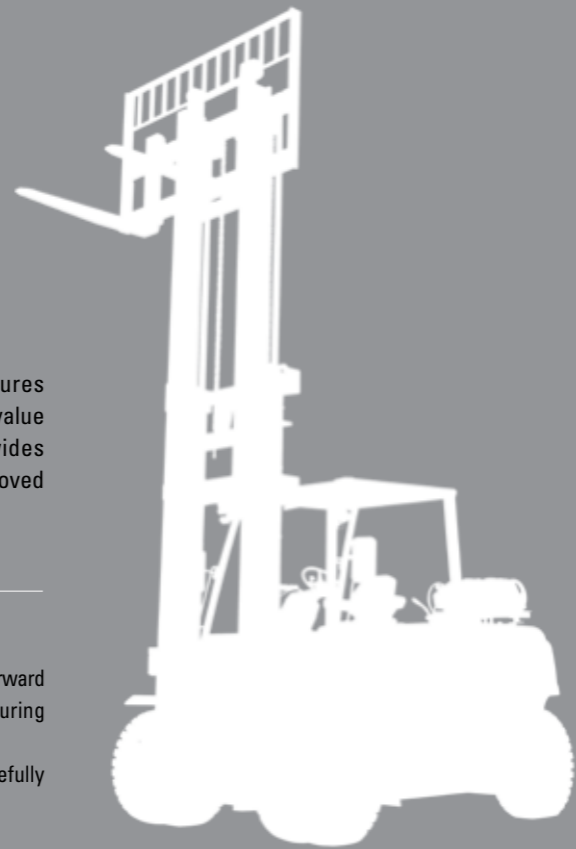

Some of the photos may include optional equipment.

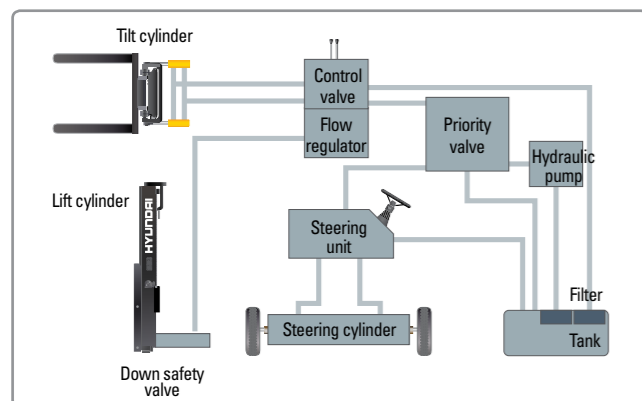

State-of-the-art Hydraulic System

The latest large-capacity hydraulic system reacts quickly during operation, and a low-noise control valve increases both efficiency and durability.



Fully Hydrostatic Power Steering

A hydraulic steering system always guarantees smooth and flexible steering, preventing overrun and kick-back.



Increased Mast Tilting Angle

Utilizing the mast tilting angle of 15 degrees forward and 10 degrees backward, the operator can safely and rapidly perform loading and unloading jobs.

Faster Travel Speed & Better Gradability

The powerful high-output engine provides greater acceleration, better gradability and faster travel speed on any tough terrains or slopes.

Gradability(Loaded)

60L-7A : 45.6%
70L-7A : 40.6%

Travel Speed(Unloaded)

60L-7A : 22.4 km/h
70L-7A : 22.5 km/h



Ergonomic operator friendly compartment design!

A design based on human engineering relieves fatigue and increases operator's efficiency.

Operator Friendly Gauges and Water-resistant Monitor Panel



- 1 Parking brake lamp
- 2 Turn lamp
- 3 Engine oil warning lamp
- 4 Transmission oil temperature warning lamp
- 5 Battery charging warning lamp
- 6 Air cleaner filter warning light
- 7 Working light indicator
- 8 Seat belt warning
- 9 Water temperature gauge
- 10 OPS warning (option)
- 11 Hour meter
- 12 Engine check lamp
- 13 Brake oil warning lamp



Full Suspension Seat
An attractive and adjustable seat, based on a human engineering design, provides great comfort, safety and durability.



New High Visibility for Safe Operation
The operator is able to work with increased safety and accuracy due to a wider view mast.



Some of the photos may include optional equipment.



Ergonomically Positioned Pedals
Based on human engineering, the accelerator, brake and inching pedals are optimally positioned for convenience while operating the equipment.



Cup Holder & Console Box
Additional storage spaces are located inside the operating space for operator's convenience.



Quick Response of Operating Control Levers
Only minimal operator's effort is required for precise, safe and productive control.



Adjustable Steering Wheel
Steering wheel with horn button can be adjusted by a lever on the right-hand side for the most comfortable operator position.



Easy and Safe Shift Lever
A single lever on the left side of the steering column gives the operator fast, easy control of direction. The lever must be in the neutral position before the engine can be started.



Secondary Horn
Secondary Horn gives access to lights and horn.

Danger-free through high durability!

Safety and durability are priorities in design of the equipment.

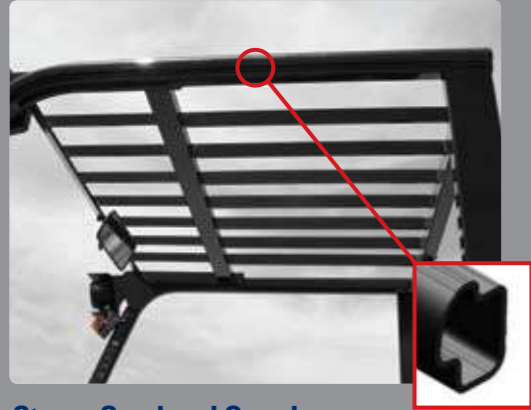

Strong Overhead Guard

The safety overhead guard meets ISO 6055 regulation and protects the operator during hazardous jobs.



Parking brake

Ratchet type parking brake requires less effort the operator to set.

Highly Durable Split type Drive Axle

The planetary reduction drive axle smoothly delivers desired torque to the drive wheels.



Some of the photos may include optional equipment.

OPSS (Operator Presence Sensing System)

Control of mast tilting, lifting and lowering is not possible through operation of the appropriate control when the operator is not in the seated position. (Option)



Large Footboard & Hand Grip

Wide "open" step offers convenience and safety when entering and exiting truck.

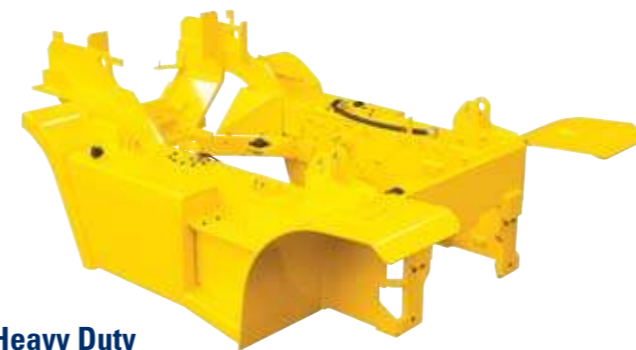

Heavy Duty Single Unit Frame

Heavy duty single unit type frame, designed on the basis of accurate structural analysis, guarantees durability and safety.



Bright, Protected Headlights

Bright, Protected head lights are positioned for exceptional visibility.

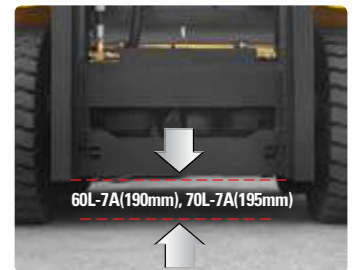

Ground Clearance

The engine and transmission are assembled horizontally and positioned high in the frame to protect major components during operation on rugged surface.

Designed for quick and easy service!

An ideal arrangement of component parts ensures easy access and convenience for maintenance.



Large Engine Hood
Highly accessible engine compartment assures fast and efficient maintenance.



Easy Change Air Cleaner
The air filter is readily accessible for cleaning or replacement.



Up-to-date Cooling System



■ Some of the photos may include optional equipment.



Brake Fluid Reservoir with Level Switch
When brake oil level became lower than Min., the warning lamp on the cluster lights on.



Easy Maintenance Oil Check
The T/M oil level can be checked easily without any disassembly.



Expansion Bellows
The expansion bellows absorbs vibration and reduces noise generated from the exhaust system and also extends the life cycle of exhaust system.



Grease Fittings
Grease fittings are installed for fast access to steering axle center pin when doing your service checks.



Maintenance Free Battery



Large Tool Box
Additional tool box located in machine side for operator's convenience.



Easy-to-access Reservoir Tank



Wing Cover Locking System

Mast Specification

Model	Mast Type	Maximum Fork Height (mm)	Overall Height(mm)				Free Lift (mm)		Tilt Angle (deg)		Load Capacity without side shift at 600mm LC(kg)	Load Capacity with side shift at 600mm LC(kg)	Truck Weight (Unloaded)(kg)
			Lowered	Extended		Without Load Backrest	With Std Load Backrest	Fwd	Bwd				
				W/o Load Backrest	W/Std Load Backrest								
60L-7A	2 Stage limited free lift	V270	2,730	2,365	3,911	4,020	140	140	15	10	6,000	6,000	8,779
		*V300	3,030	2,515	4,211	4,320	140	140	15	10	6,000	6,000	8,826
		V330	3,330	2,665	4,511	4,620	140	140	15	10	6,000	6,000	8,874
		V350	3,530	2,765	4,711	4,820	140	140	15	10	6,000	6,000	8,906
		V370	3,730	2,865	4,911	5,020	140	140	15	10	6,000	6,000	8,938
		V400	4,030	3,015	5,211	5,320	140	140	15	10	6,000	6,000	8,994
		V450	4,530	3,315	5,711	5,820	140	140	15	10	6,000	6,000	9,221
		V500	5,030	3,565	6,211	6,320	140	140	15	10	6,000	5,850	9,301
		V550	5,530	3,815	6,711	6,820	140	140	15	10	6,000	5,650	9,381
		V600	6,030	4,065	7,211	7,320	140	140	15	10	6,000	5,500	9,459
3 Stage full free lift	TF450/TS450	4,560	2,565	5,765	5,805	1,360	1,275	15	10	6,000	5,750	9,430	
	TF500/TS500	5,060	2,765	6,265	6,305	1,560	1,475	15	10	6,000	5,600	9,522	
	TF560/TS560	5,600	2,965	6,805	6,845	1,760	1,675	15	10	5,950	5,400	9,633	
	TF600/TS600	6,060	3,165	7,265	7,305	1,960	1,875	15	10	5,750	5,250	9,720	

*Standard : Hook-on Type Fork & Carriage

Load Capacity

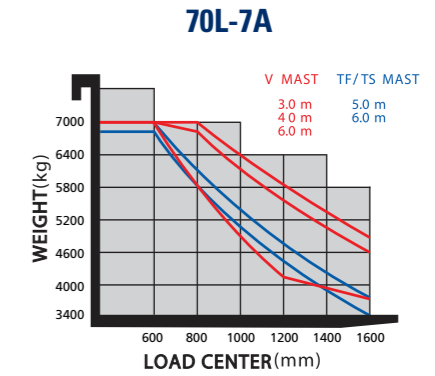
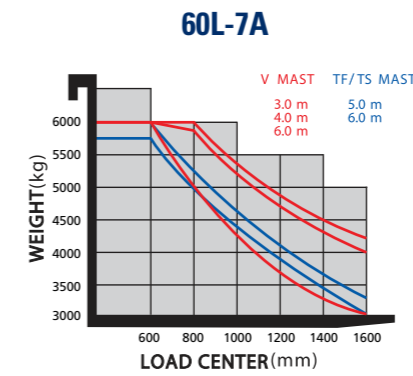

Various Attachments

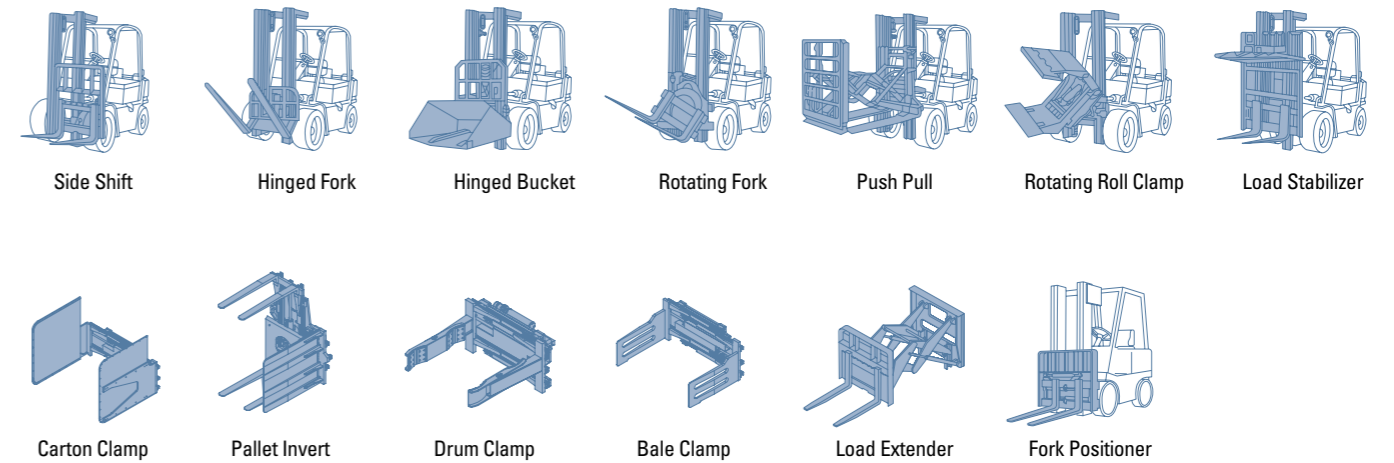

Model	Mast Type	Maximum Fork Height (mm)	Overall Height(mm)				Free Lift (mm)		Tilt Angle (deg)		Load Capacity without side shift at 600mm LC(kg)	Load Capacity with side shift at 600mm LC(kg)	Truck Weight (Unloaded)(kg)
			Lowered	Extended		Without Load Backrest	With Std Load Backrest	Fwd	Bwd				
				W/o Load Backrest	W/Std Load Backrest								
70L-7A	2 Stage limited free lift	V270	2,730	2,365	3,911	4,020	140	140	15	10	7,000	7,000	9457
		*V300	3,030	2,515	4,211	4,320	140	140	15	10	7,000	7,000	9506
		V330	3,330	2,665	4,511	4,620	140	140	15	10	7,000	7,000	9552
		V350	3,530	2,765	4,711	4,820	140	140	15	10	7,000	7,000	9584
		V370	3,730	2,865	4,911	5,020	140	140	15	10	7,000	7,000	9616
		V400	4,030	3,015	5,211	5,320	140	140	15	10	7,000	7,000	9672
		V450	4,530	3,315	5,711	5,820	140	140	15	10	7,000	6,900	9900
		V500	5,030	3,565	6,211	6,320	140	140	15	10	7,000	6,700	9979
		V550	5,530	3,815	6,711	6,820	140	140	15	10	7,000	6,500	10059
		V600	6,030	4,065	7,211	7,320	140	140	15	10	6,800	6,350	10137
3 Stage full free lift	TF450/TS450	4,560	2,565	5,765	5,805	1,360	1,275	15	10	7,000	6,600	10095	
	TF500/TS500	5,060	2,765	6,265	6,305	1,560	1,475	15	10	6,900	6,400	10187	
	TF560/TS560	5,600	2,965	6,805	6,845	1,760	1,675	15	10	6,700	6,200	10298	
	TF600/TS600	6,060	3,165	7,265	7,305	1,960	1,875	15	10	6,500	6,050	10386	

*Standard : Hook-on Type Fork & Carriage

Optional Items

- **FORK (mm)**
· 1,350 / 1,500 / 1,800 / 2,000 / 2,400
- **OVER SHOE**
1,800 / 2,000 / 2,200 / 2,300
- **SOLID NON-MARKING**
- **SEAT** : SEAT BELT, ARM REST, HIP REST
- **INTERNAL PIPING**
- **CABIN & HEATER**
CABIN, HEATER
- **MUFFLER** : HORIZONTAL
- **LPG TANK CLAMP** : DUAL
- **MASTER SWITCH**
- **ELE.BEACON**
- **HAZARD SWITCH**
- **MCV** : 3-SPOOL / 4-SPOOL / 5-SPOOL
- **INTEGRAL FORK POSITIONER CARRIAGE**
- **INTEGRAL SIDE SHIFT CARRIAGE**
- **INTEGRAL S/S WITH F/P CARRIAGE**